



SETRON switch disconnecter 3LD in molded-plastic enclosure , repair and maintenance switch with EMC plate, 6-pole lu: 25A, AC23A 400V at 50/60Hz: 9,5kW, used with frequency converter: AC20 400V at 0-550Hz: 5,5kW, 1NO + 1NC 20-150ms leading, molded-plastic encapsulation for metric cable gland, knob-operated mechanism, black, lockable in 0- and I-position, incl. cable shield clamps

Model	
product brand name	SETRON
product designation	3LD Switch disconnecter
design of the product	Switch
display version / for switch position indicator manual operation	1 ON - 0 OFF
type of switch	Molded-plastic enclosure for metric threaded joint
design of the actuating element	selector switch
color / of the actuating element	black
design of handle	knob-operated mechanism, black
type of the driving mechanism / motor drive	No
General technical data	
number of poles	6
number of poles / note	PE isolated from cable shield
size of switch disconnecter	2
mechanical service life (switching cycles) / typical electrical endurance (switching cycles)	100 000
<ul style="list-style-type: none"> at AC-23 A / at 690 V between converter and motor / when used as repair switch / at AC-20 A / at 690 V / at 0-550 Hz 	6 000 100 000
operating frequency / maximum	50 1/h
degree of pollution	3
Voltage	
insulation voltage / rated value	690 V
surge voltage resistance / rated value	6 kV
operating voltage	690 V
<ul style="list-style-type: none"> between converter and motor / at AC / at 0-550 Hz / rated value 	690 V
Protection class	
protection class IP	IP65
degree of protection NEMA rating	1, 3R, 4X
protection class IP / on the front	IP65
Dissipation	
power loss [W] / for rated value of the current / at AC / in hot operating state / per pole	1.1 W
Current	
operational current / rated value	25 A
operational current	25 A
<ul style="list-style-type: none"> at AC / rated value 	25 A
Main circuit	

operating frequency / between converter and motor / when used as repair switch	
<ul style="list-style-type: none"> initial value full-scale value 	<p>0 Hz</p> <p>550 Hz</p>
operational current	
<ul style="list-style-type: none"> at AC-21 / at 690 V / rated value at AC-21 A / at 240 V / rated value at AC-21 A / at 400 V / rated value at AC-21 A / at 440 V / rated value at AC-23 A / at 400 V / rated value 	<p>25 A</p> <p>25 A</p> <p>25 A</p> <p>25 A</p> <p>20 A</p>
operating power	
<ul style="list-style-type: none"> at AC-23 A / at 240 V / rated value at AC-23 A / at 440 V / rated value at AC-23 A / at 690 V / rated value at AC-3 / at 240 V / rated value at AC-3 / at 400 V / rated value at AC-3 / at 690 V / rated value 	<p>5 kW</p> <p>9.5 kW</p> <p>10 kW</p> <p>4 kW</p> <p>8 kW</p> <p>7.5 kW</p>
operating active power [W] / between converter and motor / when used as repair switch / at AC-20 A	
<ul style="list-style-type: none"> at 400 V / at 0-550 Hz / rated value at 690 V / at 0-550 Hz / rated value 	<p>5.5 kW</p> <p>11 kW</p>
continuous current / between converter and motor / when used as repair switch / at AC-20	
<ul style="list-style-type: none"> at 230 V / rated value at 400 V / rated value at 690 V / rated value 	<p>17.5 A</p> <p>13.2 A</p> <p>14 A</p>
Auxiliary circuit	
number of CO contacts / for auxiliary contacts	0
number of NC contacts / for auxiliary contacts	1
number of NO contacts / for auxiliary contacts	1
operating voltage / of auxiliary contacts / at AC / maximum	600 V
continuous current / of the auxiliary contact / rated value	10 A
insulation voltage / of the auxiliary switch / rated value	500 V
Suitability	
suitability for use	
<ul style="list-style-type: none"> main switch switch disconnector EMERGENCY OFF switch safety switch maintenance/repair switch 	<p>Yes</p> <p>Yes</p> <p>No</p> <p>No</p> <p>Yes</p>
Product details	
product feature / can be locked in ON position	Yes
special product feature	inclusive EMC shield plate
product feature / can be locked into OFF position	Yes
accessories	
product extension / optional	
<ul style="list-style-type: none"> motor drive voltage trigger 	<p>No</p> <p>No</p>
number of connectable NC contacts / for auxiliary contacts / attachable / maximum	2
number of connectable NO contacts / for auxiliary contacts / attachable / maximum	4
number of connectable CO contacts / for auxiliary contacts / attachable / maximum	0
number of bracket locks / maximum	3
hasp thickness / of the bracket locks	4.5 ... 8.5 mm
Short circuit	
conditional short-circuit current / with line-side fuse protection	
<ul style="list-style-type: none"> at 690 V / by gG fuse / rated value 	50 kA
let-through current / with closed switch	

<ul style="list-style-type: none"> at 240 V / for combination switch + gG fuse / maximum 	3.5 kA
<ul style="list-style-type: none"> at 440 V / for combination switch + gG fuse / maximum 	3.5 kA
<ul style="list-style-type: none"> at 690 V / for combination switch + gG fuse / maximum permissible 	4 kA
I _{2t} value / with closed switch / at 240 V / for combination switch + gG fuse / maximum	4 kA ² .s
I _{2t} value / with closed switch / at 440 V / for combination switch + gG fuse / maximum	4 kA ² .s
I _{2t} value / with closed switch / at 690 V / for combination switch + gG fuse / maximum	4 kA ² .s
design of the fuse link	
<ul style="list-style-type: none"> for short-circuit protection of the main circuit / required 	fuse gL/gG: 25 A
<ul style="list-style-type: none"> for short-circuit protection of the auxiliary switch / required 	fuse gL/gG: 10 A
operational current / of upstream fuse / rated value	25 A
according UL	
operational current / at AC / according to UL 508/UL 60947-4-1 / rated value	25 A
operating voltage / at AC / at 50/60 Hz / according to UL 508/UL 60947-4-1 / rated value	600 V
active power [hp] / at AC / at 480 V / according to UL 508/UL 60947-4-1 / rated value	10
active power [hp] / at AC / at 600 V / according to UL 508/UL 60947-4-1 / rated value	15
short-time withstand current (SCCR) / at 600 V / according to UL 508/UL 60947-4-1	5 kA
continuous current / of upstream fuse / according to UL / rated value	50 A
type of fuse / according to UL	RK5
Connections	
AWG number / as coded connectable conductor cross section / solid	
<ul style="list-style-type: none"> maximum 	8
<ul style="list-style-type: none"> minimum 	14
type of connectable conductor cross-sections / for copper conductor	
<ul style="list-style-type: none"> solid 	1x (1,5...16mm ²)
<ul style="list-style-type: none"> finely stranded / with core end processing 	1x (1,5...10mm ²)
<ul style="list-style-type: none"> stranded 	1x (1,5...16mm ²)
type of connectable conductor cross-sections / for auxiliary contacts	
<ul style="list-style-type: none"> solid 	lateral auxiliary switch 2x (0,75 ... 2,5mm ²), 1x 4mm ² ; front auxiliary switch 1x (0,75 ... 2,5mm ²)
<ul style="list-style-type: none"> finely stranded / with core end processing 	lateral auxiliary switch 2x (0,75 ... 1,5mm ²), 1x 2,5mm ² ; front auxiliary switch 1x 2,5mm ²
<ul style="list-style-type: none"> stranded 	lateral auxiliary switch 2x (0,75 ... 2,5mm ²), 1x 4mm ² ; front auxiliary switch 1x (0,75 ... 2,5mm ²)
type of electrical connection	
<ul style="list-style-type: none"> for main current circuit 	box terminal
<ul style="list-style-type: none"> for auxiliary contacts 	connection terminals
Mechanical Design	
height	199 mm
width	146 mm
depth	149 mm
type of device	fixed mounting
fastening method	Complete unit in enclosure with EMC shield plate
fastening method	
<ul style="list-style-type: none"> 4-hole front mounting 	No
<ul style="list-style-type: none"> front mounting with central attachment 	Yes
<ul style="list-style-type: none"> rail mounting 	No
net weight	760 g

Environmental conditions

ambient temperature / during operation	
• minimum	-25 °C
• maximum	55 °C
ambient temperature / during storage	
• minimum	-25 °C
• maximum	55 °C

General Product Approval

Declaration of Conformity

[Confirmation](#)



Test Certificates

other

[Miscellaneous](#)

[Miscellaneous](#)

[Environmental Con-
firmations](#)

Further information

Information- and Downloadcenter (Catalogs, Brochures,...)

<http://www.siemens.com/lowvoltage/catalogs>

Industry Mall (Online ordering system)

<https://mall.industry.siemens.com/mall/en/en/Catalog/product?mlfb=3LD2185-5VD21>

Service&Support (Manuals, Certificates, Characteristics, FAQs,...)

<https://support.industry.siemens.com/cs/ww/en/ps/3LD2185-5VD21>

Image database (product images, 2D dimension drawings, 3D models, device circuit diagrams, ...)

http://www.automation.siemens.com/bilddb/cax_en.aspx?mlfb=3LD2185-5VD21

CAX-Online-Generator

<http://www.siemens.com/cax>

Tender specifications

<http://www.siemens.com/specifications>

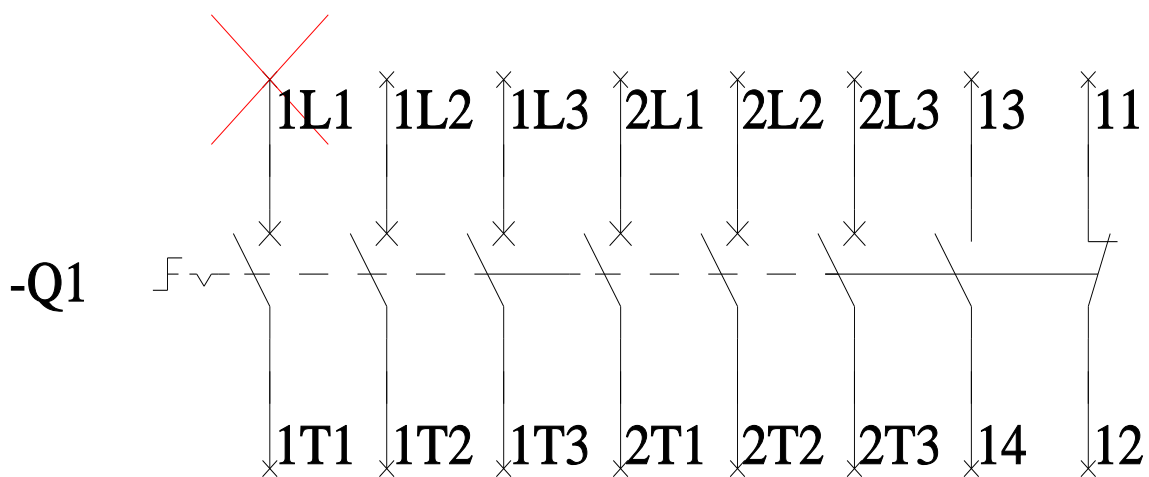
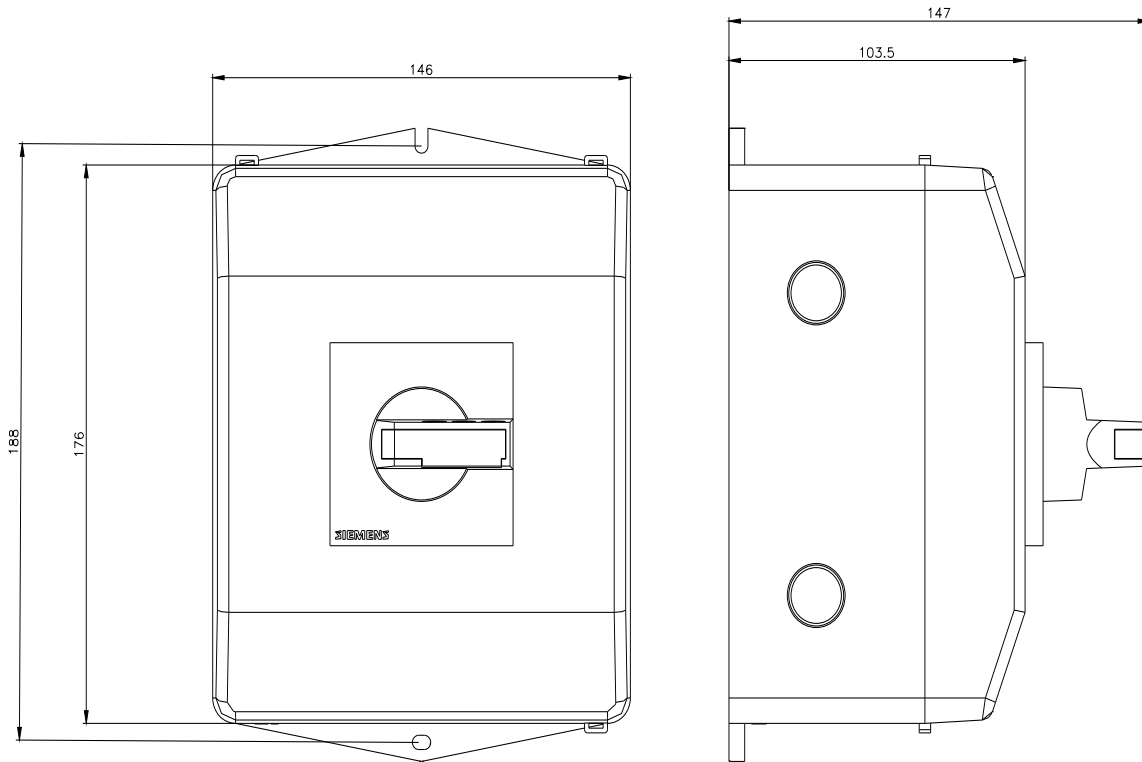

-CI

